

Δ-p-SENSOR-TRANSMITTER DMC-4-

Z 9884232_004_DMC4_GB, subject to change, date 09.04.2015, valid as of device number 106525

1. Service instructions :

● LED green: Power

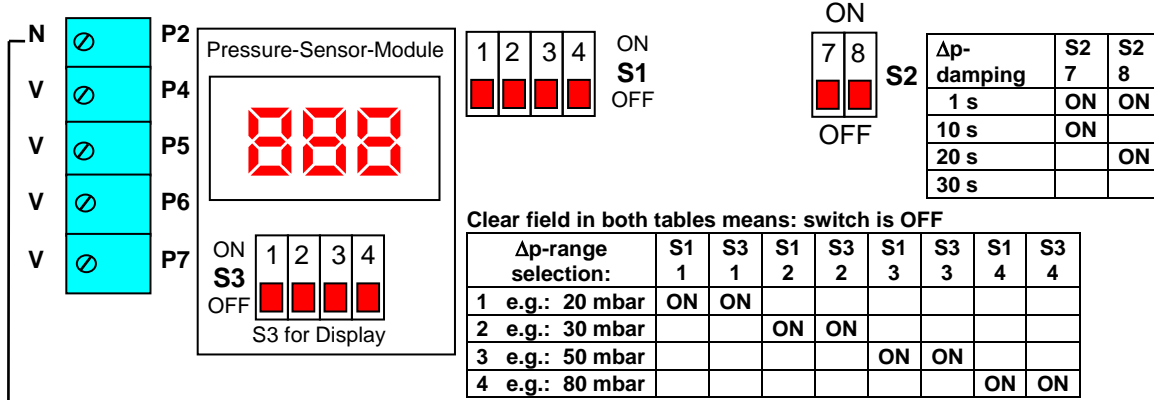

Trimmer-Potis P2 - P9 :

P2 = N = Zero point for all ranges
 P4 = V = End of scale value, range 1. P5 = V = End of scale value, range 2
 P6 = V = End of scale value, range 3. P7 = V = End of scale value, range 4

When using a Δp-SENSOR-TRANSMITTER with a range of ≤ 20 mbar, please consider the following:

Pot. N = zero point. If the appliance has not been transported vertically (gravity influence on the sensor membrane), please adjust the zero point with P2 as soon as the operating temperature has been reached. Please make sure that the damping-switch S2 is in Iposition 1s during the adjustment. With the **DIP-Switch S6**, on the right-hand side of terminal 13, the analogue output at terminal 12 can be changed from 0-20 mA, S6 = ON to 4-20 mA, S6 = OFF.

2. Electric connection diagram:

2.1 DMC-4 - 24 - DC-

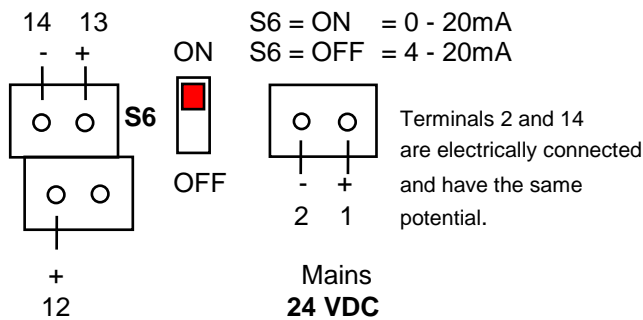

2.2 DMC-4 - 240 - AC -

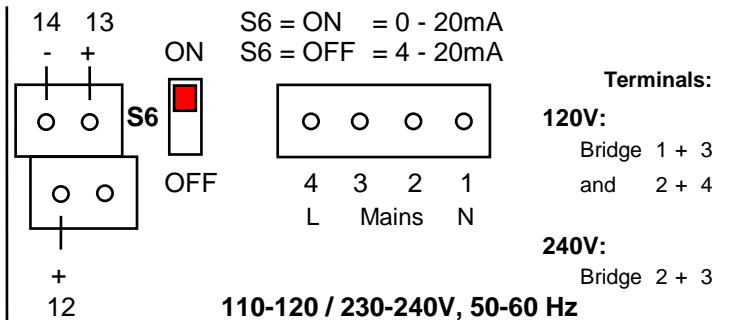

Analogue outputs:

- 0-10 V = load ≥ 5 kΩ, terminal14- (or terminal 2- only for 24 VDC) and terminal 13+, S6 = ON or OFF
- 0-20 mA = load ≤ 500 Ω, terminal14- (or terminal 2- only for 24 VDC) and terminal 12+, S6 = ON.
- 4-20 mA = load ≤ 500 Ω, terminal14- (or terminal 2- only for 24 VDC) and terminal 12+, S6 = OFF.

Please notice that a measurement with an external instrument at the screw-head-terminals can only be carried out correctly, if the screws are completely tightened. Otherwise the contact will not be sufficient and the instrument does not display the correct data.

3. Mounting instructions:

4 borings in the back panel of the housing : ID = 4.2 mm, 50 x 108,5 mm. Please mount the back panel vertically. Consider also point 1 'service instructions'. For entering cables, only use plastic connectors. If you use only **one** pressure connection (+ or -), then the other one that remains unused must be open and protected against dust and dirt. For this reason please use our FILTER FS-* or a tube placed in a dust-free room. If the measurement tubes (positive/negative pressure) could get dirty, please install our FILTER FT* or our PIPE-CLEANER PPC*.

Attention ! with pressure connectors 64, 86, 64MS: In order to tighten or remove the nuts of the pressure connections, please use an open-jawed spanner 12 mm (for 86 = 14 mm). The screwed connection at the appliance must in this case be fixed with a 13 mm spanner to avoid torsion. Otherwise, the appliance could be damaged.

MIKRO-MESS-GMBH

D - 31275 Lehrte,

Phone: ++49 (0)5136 880 990 8,

Am Südende 15 - Steinwedel

FAX: ++49 (0)5136 880 990 0

Internet: www.mikro-mess.de

E-Mail: info@mikro-mess.de