

Δp – SENSOR – TRANSMITTER DMQ*-RAD

Wiring diagram:

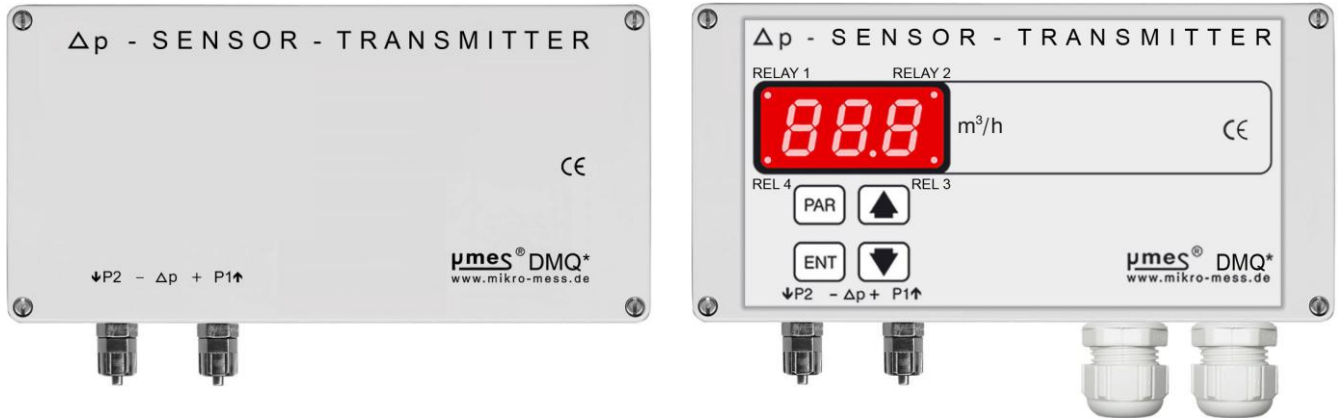

1. Wiring diagram:

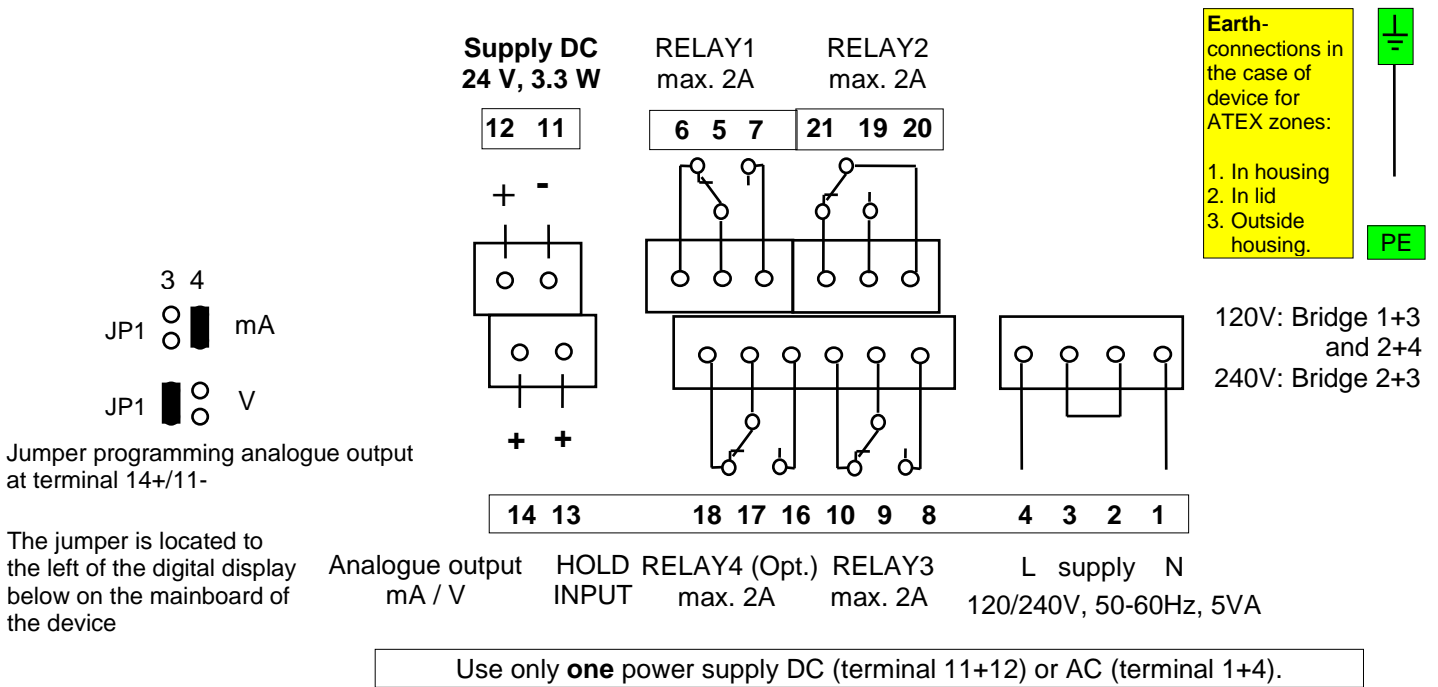

1.1. Supply voltage / signal output:

The nominal supply voltage and the admissible tolerance as well as the admissible load/burden for the analogue output and the admissible applied load of the switching outputs is stated in the data sheet.